

# Gegenring Type C/CS

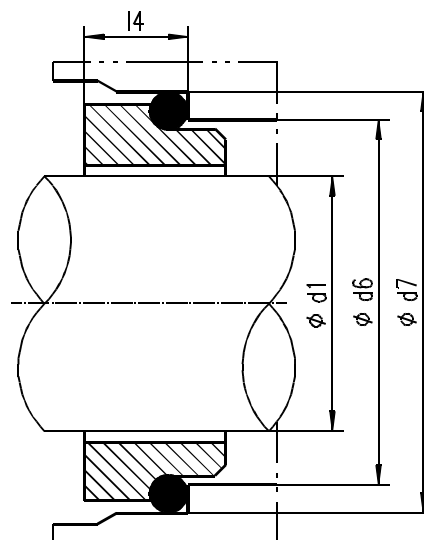

Werkstoffe		
Gegenring:	SIC	(U31)
	Kohle	(Z31)
	Chromguss	(Y1)
	Edelstahl	(E)
	Elastomer:	Viton
	EPDM	(D)
	FEP	(V2)

			Typ C	Typ CS
d <sub>1</sub>	d <sub>6</sub>	d <sub>7</sub>	l <sub>4</sub>	l <sub>4</sub>
10	17	21	10,0	6,6
12	19	23	10,0	6,6
14	21	25	10,0	6,6
15	21	27	10,0	6,6
16	23	27	10,0	6,6
18	27	33	10,0	7,5
20	29	35	10,0	7,5
22	31	37	10,0	7,5
24	33	39	10,0	7,5
25	34	40	10,0	7,5
28	37	43	10,0	7,5
30	39	45	10,0	7,5
32	42	48	10,0	7,5
33	42	48	10,0	7,5
35	44	50	10,0	7,5
38	49	56	11,0	9,0
40	51	58	11,0	9,0
43	54	61	11,0	9,0
45	56	63	11,0	9,0
48	59	66	11,0	9,0
50	62	70	13,0	9,5
53	65	73	13,0	11,0
55	67	75	13,0	11,0
58	70	78	13,0	11,0
60	72	80	13,0	11,0
65	77	85	13,0	11,0
68	81	90	15,0	11,3
70	83	92	15,0	11,3
75	88	97	15,0	11,3
80	95	105	15,5	12,0
85	100	110	15,5	14,0
90	105	115	15,5	14,0
95	110	120	15,5	14,0
100	115	125	15,5	14,0

Änderungen jederzeit vorbehalten